

# ServoCenterMidi™ v1.2a

## **User's Manual & Programming Guide**

Yost Engineering, Inc.  
630 Second Street  
Portsmouth, Ohio 45662

[www.YostEngineering.com](http://www.YostEngineering.com)

©2002-2005 Yost Engineering, Inc.  
Printed in USA

## Table of Contents

<b>1. Package Checklist.....</b>	<b>3</b>
<b>2. Function Overview.....</b>	<b>3</b>
1.2 Introduction.....	3
2.2 Board Overview.....	4
2.3 Features and Specifications.....	6
2.3.1 Features.....	6
2.3.2 Specifications.....	6
Physical.....	6
Interface.....	6
Electrical.....	6
<b>3 Installation.....</b>	<b>7</b>
3.1 General Installation Precautions.....	7
3.2 Connecting a Single ServoCenterMidi 1.2 Board.....	7
3.3 Connecting Multiple ServoCenterMidi 1.2 Boards.....	8
3.4 Jumper Settings.....	10
3.4.1 Jumper JP1.....	10
3.4.2 Jumper JP2.....	10
3.5 MIDI Channel Settings.....	11
<b>4 Using the ServoCenterMidi 1.2.....</b>	<b>12</b>
4.1 ServoCenterMidi Usage Overview.....	12
4.2 MIDI Implementation.....	13
4.1.2 Low Range Servo Mapping.....	13
4.2.2 High Range Servo Mapping.....	14
4.2.3 Additional MIDI Controller Messages.....	15
<b>5. Appendix.....</b>	<b>16</b>
5.1 Hexadecimal/Decimal/Binary Conversion Chart.....	16

# 1. Package Checklist

When you purchase this product you receive the following items:

- ServoCenterMidi 1.2 Controller Board
- Midi Cable
- AC Adaptor ( 9VDC@1500ma, Positive Center)
- ServoCenterMidi 1.2 User's Manual & Programming Guide

Attention: The ServoCenterMidi 1.2 Controller Board contains static sensitive devices. Avoid touching the circuitry on the board and always handle the board by the edges only.

Caution: Fully read this instruction manual before operating the ServoCenterMidi 1.2. Misuse of the ServoCenterMidi 1.2 board could result in equipment damage or injury.

## 2. Function Overview

### 1.2 Introduction

The ServoCenterMidi 1.2 is an embedded controller that allows any device with a MIDI ( Musical Instrument Digital Interface ) OUT port to control standard hobby servo motors via MIDI "Continuous Controller" messages. Each board provides for the MIDI Continuous Controller messages to easily control the seek position up to sixteen connected servos.

The ServoCenterMidi controller also offers jumper selectable controller range setting, switch selectable MIDI channel settings, and flexible power options.

The controller's ease of use and flexible feature set make ServoCenterMidi 1.2 especially useful for servo control applications such as robotics, animatronics, motion control, automation, retail displays, and other areas where MIDI music messages are to be coordinated with fluid servo motion. The broad range of MIDI sequencer software and MIDI controller devices make creating and storing servo motor motion performances easy for non-programmers. This opens up many opportunities for multimedia displays, interactive performance art, kinetic sculptures, advertising / retail displays, etc.

Up to 16 motors can be connected to each ServoCenterMidi 1.2 board and up to 32 ServoCenterMidi 1.2 boards can be "daisy-chained" together thus allowing for a total of 512 RC servos to be controlled independently and simultaneously from one MIDI port.

The ServoCenterMidi 1.2 controller is easily configured via jumper and switch settings and is easily programmed using MIDI Continuous Controller messages.

## 2.2 Board Overview

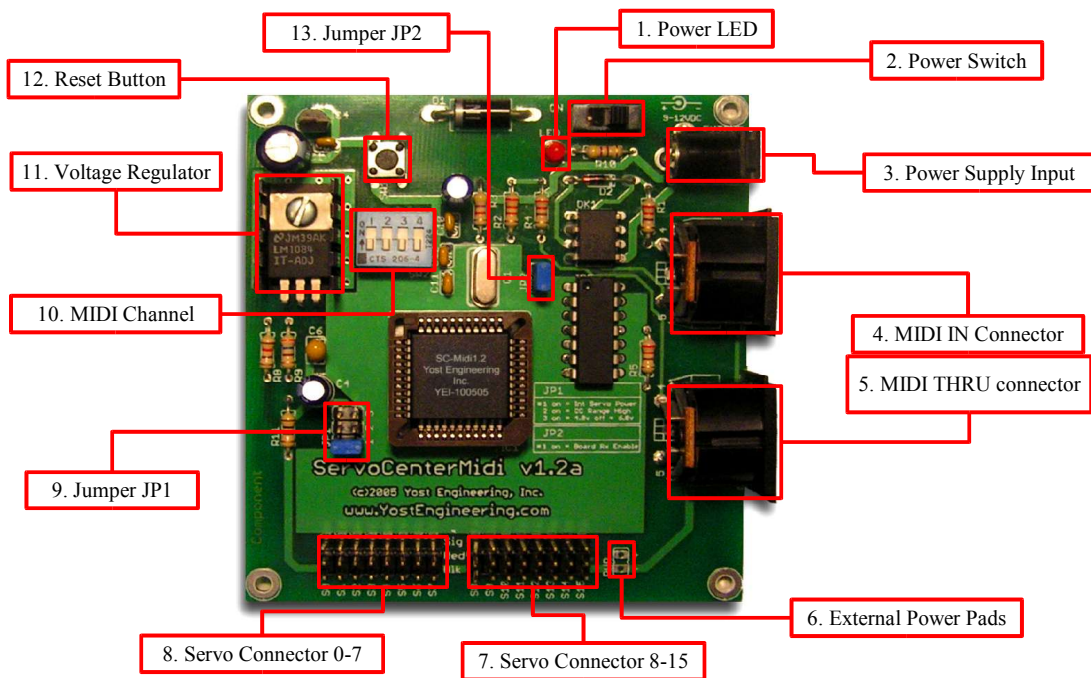

1. **Power LED** – When the power is on the power LED will be lit.
2. **Power Switch** – The power switch is used to switch the controller board and the attached servos off. The board will also not pass information from the serial IN port to the serial THRU port when turned off.
3. **Power Supply Input** – Attach a 7-15VDC power source that can supply at least 1000ma supply current. The supply connector should be a 1.2mm x 5.5mm female connector with a positive center.
4. **MIDI IN Connector** – The controller receives its control messages from this port. This port is wired as a standard MIDI IN port and should be connected with a MIDI cable to the controlling device's MIDI OUT port or to the MIDI THRU port of another device in the MIDI chain.
5. **MIDI THRU Connector** – Messages received on the MIDI IN port are amplified and sent to the MIDI THRU port. This port allows other MIDI devices ( such as additional ServoCenterMidi boards or sound sources ) to be “daisy chained”.
6. **External Power Pads** – If a jumper is installed on position 1 of JP1 then these pads act as a source of external power which may be used to power additional servos or circuitry at either 4.8Vdc or 6.0Vdc. If the jumper at position 1 of JP1 is not installed then these pads may be used to connect an external servo power source such as a battery or higher current supply.
7. **Servo Connector 8-15** – Servos 8 through 15 are connected here. The servos should always be connected so that the black ( ground ) wire of the servo is toward the outside edge of the board.
8. **Servo Connector 0-7** – Servos 0 through 7 are connected here. The servos should always be connected so that the black ( ground ) wire of the servo is toward the outside edge of the board.

9. **Jumper JP1** – Position 1 removes the on-board regulator's voltage from the servo connector when removed. It is necessary to remove this jumper when powering the servos from an external power source via the external power pads. Position 2 selects the MIDI Continuous Controller range that the board maps to the servos. When installed the servos are mapped to CC16-CC31; when not installed the servos are mapped to CC00-CC15. Position 3 selects the voltage level provided to the servos as follows: 4.8 volts when installed, 6.0 volts when removed.
  
10. **MIDI Channel Switch** – This switch determines the MIDI channel setting of the ServoCenterMidi controller board. When multiple boards are “daisy-chained” they can be distinguished from one another by using separate MIDI channel settings and CC range settings.
  
11. **Voltage Regulator** – This component supplies the power for all sixteen servos. During normal operation the regulator will get HOT. To avoid injury be careful not to touch the regulator during operation. To avoid fire do not allow combustible materials to contact the regulator during operation. The regulator circuit is equipped with both over-current and over-temperature shutdown circuitry.
  
12. **Reset Button** – This button allows the Servo Controller system to be reset without cycling the power.
  
13. **Jumper JP2** – This jumper, when installed, allows the controller to receive MIDI messages. Removing this jumper allows a board to be disabled without physically changing the wiring of a MIDI daisy chain.

## 2.3 Features and Specifications

### 2.3.1 Features

- Standard MIDI control via Continuous Controller messages.
- Control position of all 16 servos simultaneously.
- Control up to 16 RC servos per board.
- Daisy-chain up to 32 boards to control up to 512 servos from one MIDI port.
- On-board voltage regulator supports both 4.8 volt and 6.0 volt servo supply voltages.
- Over-current / over-temperature protection.
- Includes MIDI cable and 1500ma AC power supply.
- Simple MIDI protocol makes motor control simple for non-programmers.
- Jumper and switch settings allow for easy configuration.
- MIDI Continuous Controller messages can control the position of the servos and whether each servo is on or off.
- Full 14-bit resolution allows for 16384 servo positions.
- Using ServoCenterMidi 1.2 with MIDI sequencer software allows for an instant motion control solution that allows accurate and repeatable recording and playback of servo motions.

### 2.3.2 Specifications

#### Physical

**Size:** 3.375”L x 3.625”W x 1.0”H (8.5cm L x 9.2cm W x 2.5cm H)

**Weight:** 2.8 oz

#### Interface

**Input Interface:** 5-pin DIN MIDI-IN interface.

**Through Interface:** 5-pin DIN MIDI-THRU interface.

**Data Format:** MIDI Standard Interface running at 31.25kbps

**Servo Interface:** 3-pin standard universal RC servo connector.

#### Electrical

**Power Supply:** 7.5VDC – 15VDC at no less than 1000ma.

**Power Jack:** 1.2mm x 5.5mm Male Jack, Center Positive.

**Servo Power Output:** Regulated 4.8VDC or 6.0VDC (selectable)

## 3 Installation

### 3.1 General Installation Precautions

The ServoCenterMidi 1.2 board allows for several configuration options so that the user can select the option that best suits the particular requirement. In each configuration, however, the installation procedure is basically the same. When installing or configuring any ServoCenterMidi 1.2 board, observe the following:

1. Some of the electronic components are sensitive and can be damaged by electro-static discharge. Avoid touching the circuitry on the board itself and handle the board only by the edges. Place the board in a static shielding bag when storing the board for extended periods.
2. Use only the AC adaptor that was provided with the ServoCenter board. If an alternate power supply is used ensure that it is of appropriate voltage, amperage and polarity for the board.
3. When making changes in wiring, configuration, and jumper settings, be careful not to touch the voltage regulator/heat-sink. These components get hot and may cause injury if contacted.
4. The regulator and heat-sink of the ServoCenter controller get HOT during periods of heavy utilization. Avoid placing the ServoCenter board in enclosed spaces or in close proximity to combustible materials.
5. When connecting servo motors be careful to observe the polarity of the servo connectors. The black wire should be connected toward the outside edge of the board. Failure to observe the proper connector polarity could result in damage to the ServoCenter board and/or the incorrectly connected servos.
6. If an external power source such as an alternate power supply or battery is connected to the PWR connector, ensure that the jumper on position 1 of JP1 is removed.

### 3.2 Connecting a Single ServoCenterMidi 1.2 Board

Follow these steps to connect a single ServoCenterMidi 1.2 board.

1. Connect the MIDI-IN port of the ServoCenterMidi board to the MIDI OUT port of the controller ( i.e. Keyboard or other MIDI device ).
2. Connect from 1 to 16 servos to the ServoCenter board's servo ports.
3. Ensure that jumper settings are correct. ( See Section 3.4 )
4. Ensure that the MIDI Channel setting is correct. Generally MIDI Channel 1 is used in single board applications, but any MIDI Channel can be used. ( See Section 3.5 )
5. Connect the provided 9VDC@1500ma power supply to the ServoCenter board.

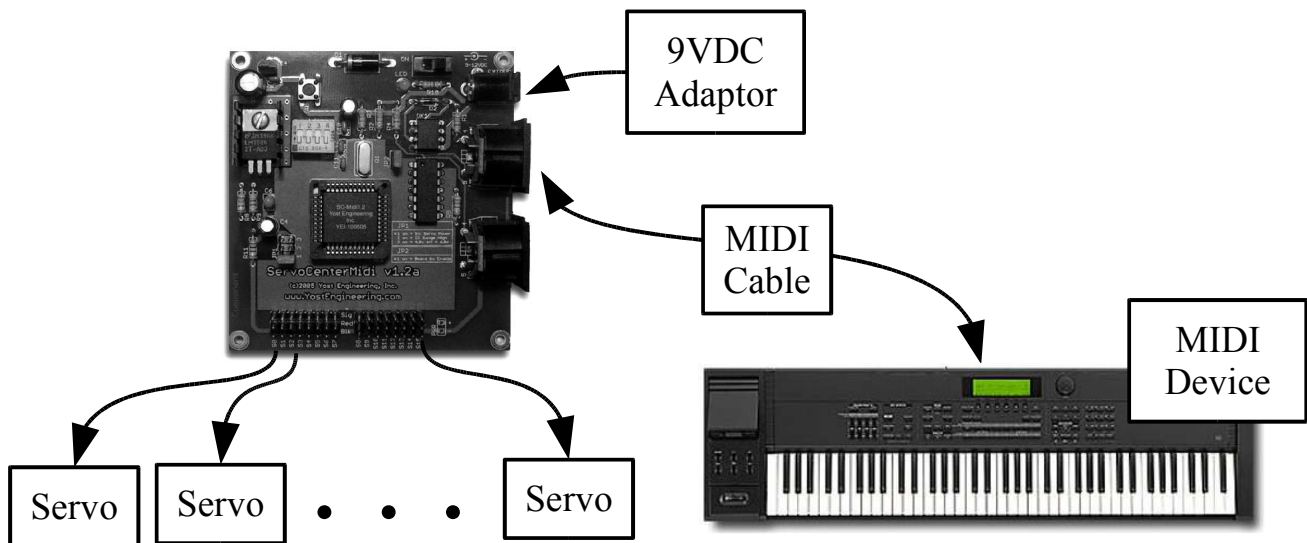

### Connecting a Single ServoCenterMidi 1.2 Controller

## 3.3 Connecting Multiple ServoCenterMidi 1.2 Boards

ServoCenterMidi 1.2 can support up to 32 boards with unique servo configurations connected together in a “daisy-chain” arrangement. This expandability allows for distinct and precise control of up to 512 servo motors.

The ServoCenter boards can be identified from one another in two ways: by assigning each board a unique MIDI Channel and/or by assigning each a different MIDI Continuous Controller range. The MIDI Channel setting is determined by the block of four switches located on the ServoCenter board. The MIDI Continuous Controller range is determined by jumper position 2 on jumper JP1.

Complete the following steps to connect multiple ServoCenterMidi 1.2 Boards:

1. Connect the MIDI-IN port of the first ServoCenter board to the MIDI-OUT port of the controlling device using a standard MIDI cable.
2. Connect the MIDI-IN port of the next ServoCenter board to the MIDI-THRU port of the previous ServoCenter board. Repeat this step for all other boards.
3. Set the MIDI Channel switches and CC Range jumpers for each board to the desired settings. This is important because this setting is what the controlling device will use to deliver commands to specific servos on specific controller modules.
4. Connect the provided 9VDC@1500ma power supplies to each ServoCenter board. Each module should be connected with a separate power supply.
5. Connect from 1 to 16 servo motors to each of the connected ServoCenter boards.

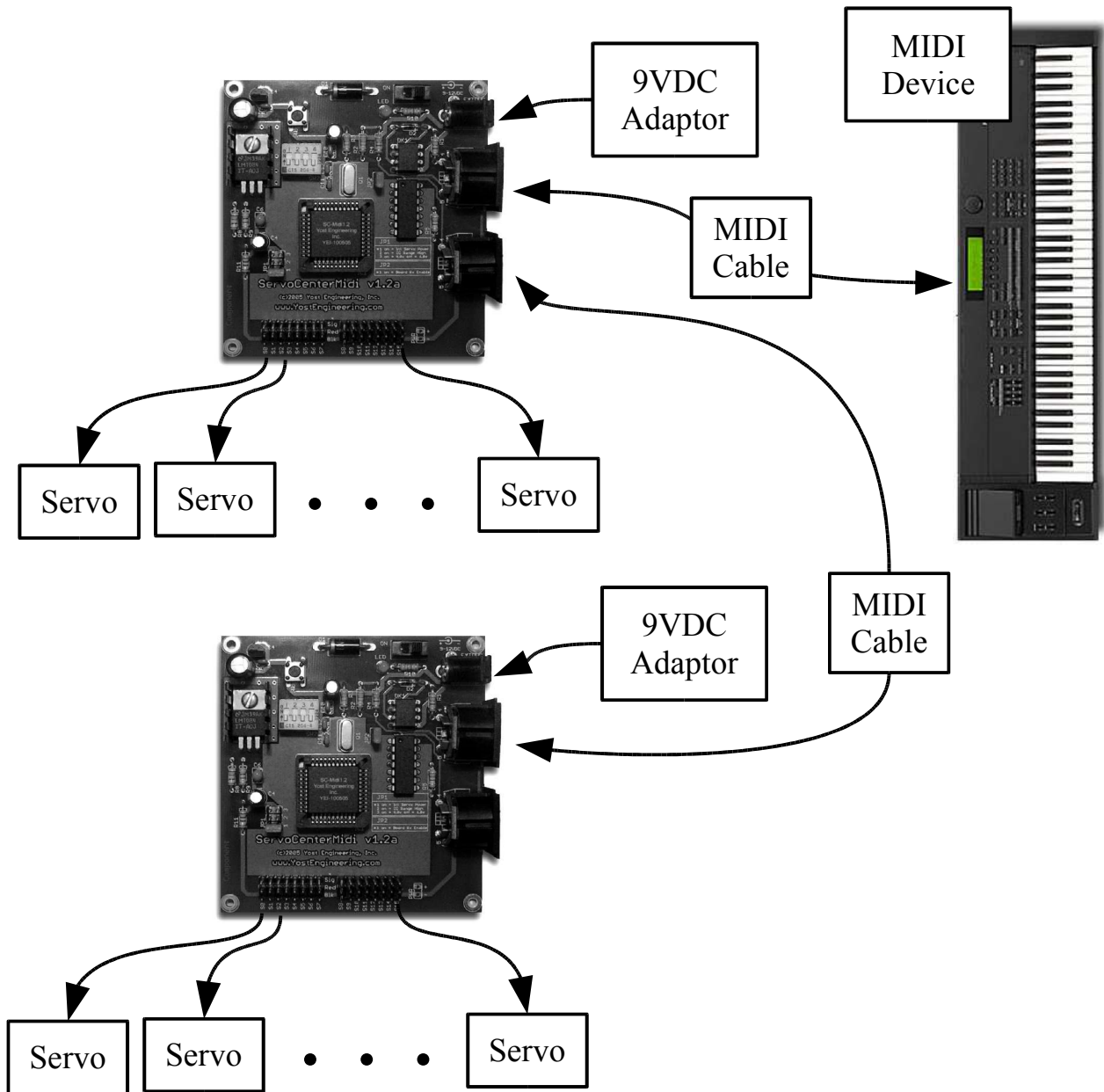

### Connecting Multiple ServoCenterMidi 1.2 Controllers

**Note:** While ServoCenterMidi 1.2 will support up to 16 unique MIDI Channels in a “daisy-chain” and two CC ranges, any number of ServoCenter boards may be assigned the same MIDI Channel and CC range. The result of this will be that all boards with the **same** MIDI Channel and CC range will simultaneously move their respective servos to the same positions. This can be done to obtain synchronized multiple servo movements or to divide high current servos across multiple boards without consuming additional board IDs.

### 3.4 Jumper Settings

The ServoCenterMidi 1.2 board has two sets of jumpers to allow various flexible software and hardware control configurations. The functionality exhibited by these jumper banks (Section 2.2 Items 9, 13) when a jumper is installed is described in each of the sections below.

#### 3.4.1 Jumper JP1

The specific functionality of jumper JP1 is as follows:

<i>Jumper JP1</i>	
<b>Position</b>	<b>Effect of Jumper When Installed</b>
1	Internal regulated servo power is connected to the servo connectors.
2	MIDI Continuous Controller range CC16-CC31 is assigned rather than CC00-CC15.
3	Servo voltage select. Regulated servo power is set to 4.8VDC when installed and 6.0VDC when removed.

When a jumper is installed in position 1, the on-board regulator supplies power to the servo connectors. When the jumper is removed from this position the regulated power is disconnected from the servo connectors. This jumper should be removed if an external power source such as a battery is used to provide the servo power via the “external power connection”. Removal of this jumper can also act as a quick method of removing power from the servos without disconnecting their wires. To avoid damage, never connect an external power source to the “external power connection” while this jumper is installed.

When a jumper is installed in position 2, servos S0 through S15 are assigned to MIDI Continuous Controller CC16-CC31 respectively. When the jumper is removed from this position servos S0 through S15 are assigned to MIDI Continuous Controller CC00-CC15 respectively. This allows two boards to share the same MIDI channel and allows the ServoCenterMidi controller to share a MIDI channel with another device.

When a jumper is installed in position 3, the on-board regulator provides 4.8VDC. When the jumper is removed from this position then the regulator provides 6.0VDC.

#### 3.4.2 Jumper JP2

Jumper JP2 controls the reception of MIDI messages by the controller. The specific functionality of jumper JP2 is as follows:

<i>Jumper JP2</i>	
<b>Position</b>	<b>Effect of Jumper When Installed</b>
1	Controller receives control messages from the MIDI-IN port.

Jumper JP2, when installed, allows the controller to receive MIDI messages. Removing this jumper allows a board to be disabled without physically changing the wiring of a MIDI daisy chain.

### 3.5 MIDI Channel Settings

The board's MIDI Channel is set via the blue bank of switches located in the upper left corner of the ServoCenterMidi 1.2 board (see Board Overview – Section 2.2 item 10). MIDI Channel numbers are determined by the position of each switch in the bank. The settings of the switch indicate the binary representation of the MIDI Channel ID number. Refer to the table below regarding the switch position/MIDI Channel relationship.

<i>Board Identification Settings</i>				
<b>1</b>	<b>2</b>	<b>3</b>	<b>4</b>	<b>MIDI Channel</b>
Off	Off	Off	Off	1
Off	Off	Off	On	2
Off	Off	On	Off	3
Off	Off	On	On	4
Off	On	Off	Off	5
Off	On	Off	On	6
Off	On	On	Off	7
Off	On	On	On	8
On	Off	Off	Off	9
On	Off	Off	On	10
On	Off	On	Off	11
On	Off	On	On	12
On	On	Off	Off	13
On	On	Off	On	14
On	On	On	Off	15
On	On	On	On	16

MIDI Channel settings can be changed any time during the operation of the ServoCenterMidi 1.2.

## 4 Using the ServoCenterMidi 1.2

### 4.1 ServoCenterMidi Usage Overview

The ServoCenterMidi 1.2 controller receives messages from the controlling MIDI device in the form of MIDI messages. The ServoCenter only responds to MIDI Continuous Controller messages and all other MIDI messages are ignored.

MIDI Continuous Controller messages are 3-bytes in length and have the following format:

Binary Format	Decimal Range	Description
1011cccc	176~191	cccc is the <b>MIDI channel</b> of the message.
0nnnnnnn	0~127	nnnnnnn is the continuous <b>controller number</b> to be changed.
0vvvvvvv	0~127	vvvvvvv is the <b>value</b> to which the controller should be changed.

Since each controller message has only a 7-bit value field, many MIDI devices ( such as the ServoCenterMidi ) utilize some controllers in pairs to achieve a full 14-bit resolution. These can be thought of as the “coarse” adjustment for the most significant 7-bits (MSB), and the “fine” adjustment for the least significant 7-bits (LSB).

Other controllers operate as switches to turn a particular parameter either off or on. This is done by treating any value greater than or equal to 64 as “on” and any value of 63 or less as “off”.

The ServoCenterMidi device uses both of these concepts to control the position and the on/off state of each motor independently.

The MIDI standard defines 32 of these 14-bit continuous controllers with 00 through 31 being the “coarse” (MSB) and 32 through 63 being the “fine”(LSB) of the value respectively. The ServoCenterMidi 1.2 uses position 2 of jumper JP1 to map these standard controllers to the motor positions of the 16 servo motors. When the jumper is removed the motors are mapped to controller 00-15 for coarse control and 32-47 for fine control. When the jumper is installed the motors are mapped to controller 16-31 for coarse control and 48-63 for fine control. If only coarse control is desired the fine controls can be ignored. See section 4.2 for specific implementation details.

ServoCenterMidi 1.2 can also turn motors on and off by using controllers 64 through 95. Controllers 64-79 turn on/off motors mapped into the 00-15 range while controllers 80-95 turn on/off motors mapped into the 16-31 range. See section 4.2 for specific implementation details.

When the board is powered on or reset, the motors, by default, are in the “off” state, meaning that they are sent no control signal and will freely turn. A motor remains in the off state until either a MIDI controller message is received for that motor or a motor on message is received for that motor.

Motors that are in the “on” state will remain on ( meaning that they'll actively hold their position ) until that motor receives a motor off message or the board is reset.

## 4.2 MIDI Implementation

### 4.1.2 Low Range Servo Mapping

When position 2 of jumper JP1 is not installed the motors are mapped to the low continuous controller range according to the following table:

Controller Number	Standard MIDI Use	ServoCenterMidi Use
00	Bank Select MSB	Servo S0 Coarse (MSB)
01	Modulation Wheel MSB	Servo S1 Coarse (MSB)
02	Breath Controller MSB	Servo S2 Coarse (MSB)
03	Undefined MSB	Servo S3 Coarse (MSB)
04	Foot Controller MSB	Servo S4 Coarse (MSB)
05	Portamento Time MSB	Servo S5 Coarse (MSB)
06	Data Entrv MSB	Servo S6 Coarse (MSB)
07	Channel Volume MSB	Servo S7 Coarse (MSB)
08	Balance MSB	Servo S8 Coarse (MSB)
09	Undefined MSB	Servo S9 Coarse (MSB)
10	Pan MSB	Servo S10 Coarse (MSB)
11	Expression Controller MSB	Servo S11 Coarse (MSB)
12	Effect Control MSB	Servo S12 Coarse (MSB)
13	Effect Control MSB	Servo S13 Coarse (MSB)
14	Undefined MSB	Servo S14 Coarse (MSB)
15	Undefined MSB	Servo S15 Coarse (MSB)
32	Bank Select LSB	Servo S0 Fine (LSB)
33	Modulation Wheel LSB	Servo S1 Fine (LSB)
34	Breath Controller LSB	Servo S2 Fine (LSB)
35	Undefined LSB	Servo S3 Fine (LSB)
36	Foot Controller LSB	Servo S4 Fine (LSB)
37	Portamento Time LSB	Servo S5 Fine (LSB)
38	Data Entrv LSB	Servo S6 Fine (LSB)
39	Channel Volume LSB	Servo S7 Fine (LSB)
40	Balance LSB	Servo S8 Fine (LSB)
41	Undefined LSB	Servo S9 Fine (LSB)
42	Pan LSB	Servo S10 Fine (LSB)
43	Expression Controller LSB	Servo S11 Fine (LSB)
44	Effect Control LSB	Servo S12 Fine (LSB)
45	Effect Control LSB	Servo S13 Fine (LSB)
46	Undefined LSB	Servo S14 Fine (LSB)
47	Undefined LSB	Servo S15 Fine (LSB)
64	Damper Pedal On/Off	Servo S0 On/Off
65	Portamento On/Off	Servo S1 On/Off
66	Sostenuto On/Off	Servo S2 On/Off
67	Soft Pedal On/Off	Servo S3 On/Off
68	Legato Footswith On/Off	Servo S4 On/Off
69	Hold 2 On/Off	Servo S5 On/Off
70	Sound Controller 1	Servo S6 On/Off
71	Sound Controller 2	Servo S7 On/Off
72	Sound Controller 3	Servo S8 On/Off
73	Sound Controller 4	Servo S9 On/Off
74	Sound Controller 5	Servo S10 On/Off
75	Sound Controller 6	Servo S11 On/Off
76	Sound Controller 7	Servo S12 On/Off
77	Sound Controller 8	Servo S13 On/Off
78	Sound Controller 9	Servo S14 On/Off
79	Sound Controller 10	Servo S15 On/Off

Note that a motor is turned back on whenever one of its corresponding controllers is changed.

Motors turned off and then turned back on will seek to the previous set position of that motor before it was turned off.

## 4.2.2 High Range Servo Mapping

When position 2 of jumper JP1 is installed the motors are mapped to the high continuous controller range according to the following table:

Controller Number	Standard MIDI Use	ServoCenterMidi Use
16	General Purpose 1 MSB	Servo S0 Coarse (MSB)
17	General Purpose 2 MSB	Servo S1 Coarse (MSB)
18	General Purpose 3 MSB	Servo S2 Coarse (MSB)
19	General Purpose 4 MSB	Servo S3 Coarse (MSB)
20	Undefined MSB	Servo S4 Coarse (MSB)
21	Undefined MSB	Servo S5 Coarse (MSB)
22	Undefined MSB	Servo S6 Coarse (MSB)
23	Undefined MSB	Servo S7 Coarse (MSB)
24	Undefined MSB	Servo S8 Coarse (MSB)
25	Undefined MSB	Servo S9 Coarse (MSB)
26	Undefined MSB	Servo S10 Coarse (MSB)
27	Undefined MSB	Servo S11 Coarse (MSB)
28	Undefined MSB	Servo S12 Coarse (MSB)
29	Undefined MSB	Servo S13 Coarse (MSB)
30	Undefined MSB	Servo S14 Coarse (MSB)
31	Undefined MSB	Servo S15 Coarse (MSB)
48	General Purpose 1 LSB	Servo S0 Fine (LSB)
49	General Purpose 2 LSB	Servo S1 Fine (LSB)
50	General Purpose 3 LSB	Servo S2 Fine (LSB)
51	General Purpose 4 LSB	Servo S3 Fine (LSB)
52	Undefined LSB	Servo S4 Fine (LSB)
53	Undefined LSB	Servo S5 Fine (LSB)
54	Undefined LSB	Servo S6 Fine (LSB)
55	Undefined LSB	Servo S7 Fine (LSB)
56	Undefined LSB	Servo S8 Fine (LSB)
57	Undefined LSB	Servo S9 Fine (LSB)
58	Undefined LSB	Servo S10 Fine (LSB)
59	Undefined LSB	Servo S11 Fine (LSB)
60	Undefined LSB	Servo S12 Fine (LSB)
61	Undefined LSB	Servo S13 Fine (LSB)
62	Undefined LSB	Servo S14 Fine (LSB)
63	Undefined LSB	Servo S15 Fine (LSB)
80	General Purpose 5	Servo S0 On/Off
81	General Purpose 6	Servo S1 On/Off
82	General Purpose 7	Servo S2 On/Off
83	General Purpose 8	Servo S3 On/Off
84	Undefined	Servo S4 On/Off
85	Undefined	Servo S5 On/Off
86	Undefined	Servo S6 On/Off
87	Undefined	Servo S7 On/Off
88	Undefined	Servo S8 On/Off
89	Undefined	Servo S9 On/Off
90	Undefined	Servo S10 On/Off
91	Effects 1 Depth	Servo S11 On/Off
92	Effects 2 Depth	Servo S12 On/Off
93	Effects 3 Depth	Servo S13 On/Off
94	Effects 4 Depth	Servo S14 On/Off
95	Effects 5 Depth	Servo S15 On/Off

Note that a motor is turned back on whenever one of its corresponding controllers is changed. Motors turned off and then turned back on will seek to the previous set position of that motor before it was turned off.

### 4.2.3 Additional MIDI Controller Messages

The ServoCenterMidi board also responds to several standard MIDI “Channel Mode” controller messages. “Channel Mode” messages affect the entire channel rather than just single control parameters. Supported “Channel Mode” messages are summarized in the following table:

Controller Number	Standard MIDI Use	ServoCenterMidi Use
120	All Sounds Off	All Servos Off. motor positions aren't modified.
121	Reset All Controllers	All Servos Off. all motor positions reset to 0 position.
123	All Notes Off	All Servos Off. motor positions aren't modified.

When either the “All Sounds Off” or “All Notes Off” channel control message is received the ServoCenterMidi controller turns off all motors without modifying their respective controller positions. Thus, if the motors are turned back on using a motor on controller message they will seek to the position that was set before the motors were turned off.

When the “Reset All Controllers” channel control message is received the board is reset to power-up default state. In this state the motor position controllers are all set to position 0 and all motors are set to an off state.

## 5. Appendix

### 5.1 Hexadecimal/Decimal/Binary Conversion Chart

Decimal	Hex	Binary
0	0	0000
1	1	0001
2	2	0010
3	3	0011
4	4	0100
5	5	0101
6	6	0110
7	7	0111
8	8	1000
9	9	1001
10	A	1010
11	B	1011
12	C	1100
13	D	1101
14	E	1110
15	F	1111