

# YEI 3-Space Sensor™

## Wireless 2.4GHz DSSS

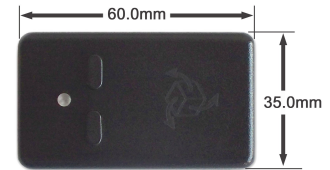

Miniature High-Performance Attitude & Heading Reference Systems / Inertial Measurement Units

### Product Overview

The YEI 3-Space Sensor™ Wireless integrates a miniature, high-precision, high-reliability, Attitude and Heading Reference System (AHRS) / Inertial Measurement Unit (IMU) with a 2.4GHz DSSS communication interface and a rechargeable lithium-polymer battery solution into a single low-cost end-use-ready unit. The Attitude and Heading Reference System (AHRS) uses triaxial gyroscope, accelerometer, and compass sensors in conjunction with advanced processing and on-board quaternion-based Kalman filtering algorithms to determine orientation relative to an absolute reference in real-time.

Orientation can be returned in absolute terms or relative to a designated reference orientation. The proprietary multi-reference vector mode increases accuracy and greatly reduces and compensates for sensor error. The YEI 3-Space Sensor Wireless system also utilizes a dynamic sensor confidence algorithm that ensures optimal accuracy and precision across a wide range of operating conditions.

The YEI 3-Space Sensor Wireless unit features are accessible via a well-documented open communication protocol that allows access to all available sensor data and configuration parameters using either 2.4GHz DSSS wireless or USB 2.0 interfaces. Versatile commands allow access to raw sensor data, normalized sensor data, and filtered absolute and relative orientation outputs in multiple formats including: quaternion, Euler angles (pitch/roll/yaw), rotation matrix, axis angle, two vector(forward/up).

### Applications

- Robotics
- Motion capture
- Positioning and stabilization
- Personnel / pedestrian navigation and tracking
- Unmanned air/land/water vehicle navigation
- Education and performing arts
- Healthcare monitoring
- Gaming and motion control
- Accessibility interfaces
- Virtual reality and immersive simulation

### Key Features

The YEI 3-Space Sensor Wireless has many features that allow it to be a flexible all-in-one solution for your orientation sensing needs. Below are some of the key features:

- Small self-contained high-performance wireless AHRS at 35mm x 60mm x 15mm and 28 grams
- Integrated 2.4GHz DSSS wireless communication interface allows high-performance at ranges up to 200'
- Integrated Lithium-Polymer battery and charge control allows battery life of 5+ hours at full performance
- Fast sensor update and filter rate allow use in real-time applications, including stabilization, virtual reality, real-time immersive simulation, and robotics
- Highly customizable orientation sensing with options such as tunable filtering, oversampling, and orientation error correction
- Advanced integrated Kalman filtering allows sensor to automatically reduce the effects of sensor noise and sensor error
- Robust open protocol allows commands to be sent in human readable form, or more quickly in machine readable form
- Orientation output format available in absolute or relative terms in multiple formats ( quaternion, rotation matrix, axis angle, two-vector )
- Absolute or custom reference axes
- Access to raw sensor data
- Flexible communication options: USB 2.0 or wireless 2.4GHz DSSS (FCC Certified)
- Communication through a virtual COM port
- USB joystick/mouse emulation modes ease integration with existing applications
- Upgradeable firmware
- RGB status LED, two programmable input buttons
- Available in either hand-held or strap-down packaging
- Each communication dongle unit supports up to 15 independent sensor units

High-reliability MEMS technology combined with advanced processing and quaternion-based Kalman filtering algorithms maintain accurate orientation outputs across a wide range of performance conditions.

**Block Diagram**

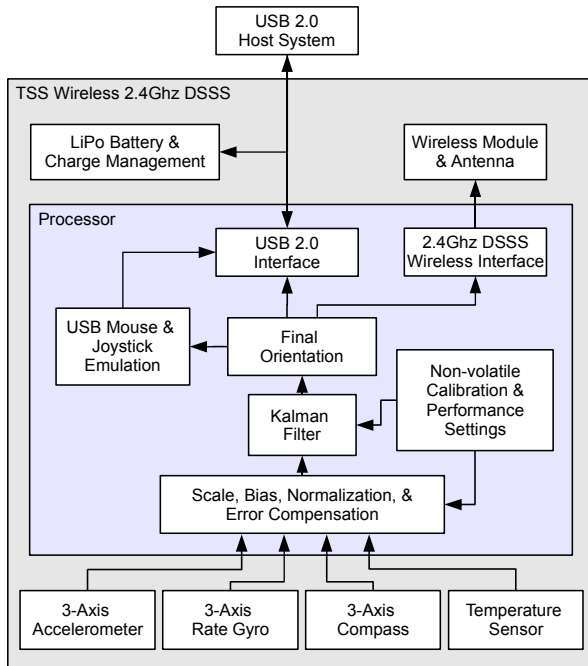

**Hardware Overview**

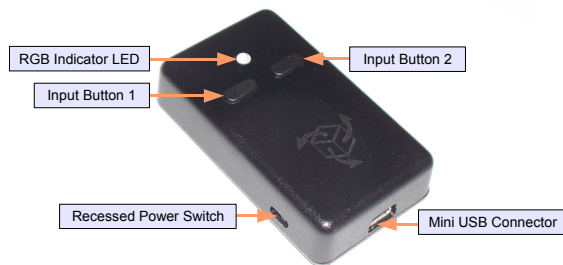

**Case Dimensions**

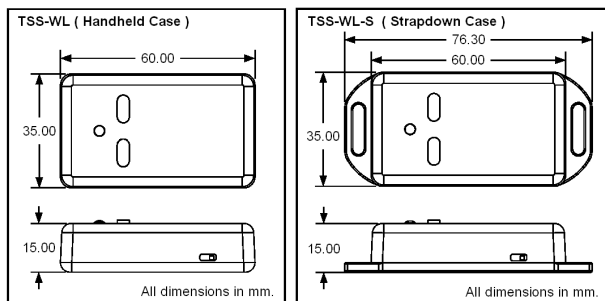

**Specifications**

General	
Part number	TSS-WL (Handheld Sensor Unit) TSS-WL-S (Strapdown Sensor Unit) TSS-DNG (Communication Dongle)
Dimensions	35mm x 60mm x 15mm (1.38 x 2.36 x 0.59 in.)
Weight	28 grams ( 0.98 oz )
Supply voltage	+5v USB
Battery technology	rechargeable Lithium-Polymer
Battery lifetime	5+ hours continuous use at full performance
Communication interfaces	USB 2.0, 2.4GHz DSSS Wireless (FCC certified)
Wireless communication range	up to 200'
Filter update rate	up to 200Hz with full AHRS functionality up to 1000Hz in IMU mode
Orientation output	absolute & relative quaternion, Euler angles, axis angle, rotation matrix, two vector
Other output	raw sensor data, normalized sensor data, temperature
Shock survivability	5000g
Temperature range	-40C ~ 85C ( -40F ~ 185F )
Sensor	
Orientation range	360° about all axes
Orientation accuracy	±2° for dynamic conditions & all orientations
Orientation resolution	<0.08°
Orientation repeatability	0.085° for all orientations
Accelerometer scale	±2g / ±4g / ±8g selectable
Accelerometer resolution	14 bit
Accelerometer noise density	99µg/√Hz
Accelerometer sensitivity	0.00024g/digit for ±2g range 0.00048g/digit for ±4g range 0.00096g/digit for ±8g range
Accelerometer temperature sensitivity	±0.008%/°C
Gyro scale	±250/±500/±2000 °/sec selectable
Gyro resolution	16 bit
Gyro noise density	0.03°/sec/√Hz
Gyro bias stability @ 25°C	11°/hr average for all axes
Gyro sensitivity	0.00875°/sec/digit for ±250°/sec 0.01750°/sec/digit for ±500°/sec 0.070°/sec/digit for ±2000°/sec
Gyro non-linearity	0.2% full-scale
Gyro temperature sensitivity	±0.016%/°C
Compass scale	±1.3 Ga default. Up to ±8.1 Ga available
Compass resolution	12 bit
Compass sensitivity	5 mGa/digit
Compass non-linearity	0.1% full-scale

Specifications are subject to change. Version: 1.0.3